



We Don't Supply Buildings
We Deliver Projects



TRAC[®] CEILINGS
TRAC[®] CEILINGS

Introduction

Interarch Building Products Pvt. Ltd. commenced operations in 1984, and pioneered the high-end metal interior products market in India. Today, 37 years later, Interarch is proud to be the leading steel building Solution provider in India with integrated facilities for Design, Manufacture, Logistics, Supply and Project Execution capabilities for pre-engineered steel buildings.



INTERARCH



TRAC[®] Ceilings

INTERARCH introduced TRAC[®] lineal metal ceilings in 1984. Today, INTERARCH is the largest manufacturer of metal building systems in India, and the product range includes pre-engineered steel buildings, metal roofing and cladding systems, metal and gypsum suspended ceilings and window covering products. All manufacturing facilities are ISO 9001 certified by Underwriters Laboratories Inc., USA.

TRAC[®] ceiling systems set the trend and command a very high market share in India. The TRAC[®] range of metal and Glass Reinforced Gypsum ceilings are specially designed for the Indian market, taking into account of building design, construction practices and weather conditions.

TRAC[®] The Right Ceiling for you

When selecting a suspended ceiling, the designer needs to weigh the costs and performance requirements. There is a TRAC[®] ceiling for every need. Ceilings systems are available in gypsum, coated steel and coated aluminium. TRAC[®] ceilings are available in a variety of designs including lineal ceilings, clip-in or lay-in tile and C-grid (band raster) ceilings. Metal ceilings are manufactured in aluminium and steel with coil coated or powder coated finishes. All metal ceilings are available in a perforated version for sound absorption, and are designed to integrate with standard lighting fixtures, air diffusers, and partitions.

Please refer to detailed product data sheets for specific applications.

TRAC[®] - THE ENVIRONMENT FRIENDLY CEILING

All TRAC[®] ceilings are manufactured from fully recyclable materials. TRAC[®] ceilings are pre-painted and fully pre-fabricated in the factory. The ceiling systems are friendly to handle, and will not promote growth of bacteria or fungi.

TRAC[®] ceilings exhibit excellent corrosion resistance. They can withstand very high humidity (upto 100%) and are suitable for use in outdoor areas.

THE RIGHT CEILING FOR THE RIGHT APPLICATION

INTERARCH is a pioneer of coated metal architectural products in India and has a consistent record of product innovation. Over the years, millions of square metres of INTERARCH architectural building products have been installed in India and abroad.

TRAC[®] ceilings are available in a wide range of panel types for decorative and functional applications. TRAC[®] ceilings are suitable for use in interior and exterior areas in offices, hospitals, schools, restaurants, shops, hotels, airports and other buildings. TRAC[®] ceilings are also suitable for industrial use and are specially suited to aggressive environments inside factory buildings.

DESIGN AND ENGINEERING SUPPORT

The Interarch Architectural Projects and Service Group (ASG) provides customers with complete design, engineering, and drafting support.

ASG can help you convert your most imaginative designs into reality. Shop drawings and detailed bill of quantities are prepared for all projects to ensure correct product supply and application.

PRODUCTS RANGE

- *Clip-in-Tile Ceilings*
- *Lay-in Grid Tile Ceilings*
- *84 C/184 C Interior & Exterior Ceilings*
- *84 R Interior & Exterior Ceilings*
- *150 F Interior & Exterior Ceilings*
- *150 C Interior Ceilings*

ACOUSTICS

Noise is major concern when designing indoor spaces. Room sound absorption is one of the most important factors in controlling built-up reverberant noise and in reducing sound transmission between rooms.

When specifying the ceiling, the architect should ensure that the specifications incorporate acoustic performance requirements.

SOUND ABSORPTION

The sound absorbing efficiency of material is designated by its sound absorption coefficient (α). This is usually measured and reported in octave bands over the frequency range of 125-4000 Hz, together with the Noise Reduction Coefficient (NRC), which is the average of the sound absorption coefficient at 250, 500, 1000 and 2000 Hz. Sound absorption coefficient data is given for all TRAC® ceilings. This enables calculation of noise reduction or reverberation time.

The increasing use of hard finishes and stone/tile finishes in offices requires the use of highly sound absorbent ceilings. TRAC® ceilings offer NRC values of 0.75 upto 1.05 for different ceiling types.

Traditionally, whenever sound absorption is required, perforated metal ceiling panels are backed with a sound absorbing layer of mineral wool or fiberglass. The use of a fibrous sound absorbing medium always has other drawbacks. These include the difficulty in working with the fibrous materials because of skin irritation and the problem of fibers letting loose into the air stream in an air-conditioned environment.

TRAC® Acousti-Panel® ceilings overcome these problems. This ceiling range comprises perforated panels with an acoustic nonwoven factory applied to the rear of the panels. Due to the controlled sound impedance of this perforated panel, and with a backing air space (ceiling plenum), the TRAC® Acousti-Panel® provides excellent sound absorption properties without the use of any fibrous material behind the perforated panel. Please refer to product data sheets for availability information.

SOUND TRANSMISSION LOSS

Sound transmission loss is a measurement of sound insulation between one room and another. Some manufacturers provide sound transmission loss (attenuation) values for ceiling tiles. This information is of doubtful utility because ceiling tiles are supported on grids and have penetrations through them to accommodate light fittings and air conditioning diffusers. The overall sound transmission loss of such a composite ceiling will be 10-20 dB lower than the transmission loss of the ceiling panel or tile alone.

When designing for sound insulation between rooms, the partition separating the rooms is of major concern. To prevent flanking sound transmission through the suspended ceiling, it is important that partitions do not stop at the ceiling, but are extended right up to the roof slab above. The suspended ceiling should not be relied upon to give sound insulation between adjacent spaces.



Sound Absorption Data

Frequency, Hz	125	250	500	1k	2k	4k	NRC
84C perf/25mm Mineral Wool/200mm air space	0.38	0.90	1.08	1.02	1.10	0.79	1.03
84R perf/25mm Mineral Wool/200mm air space	0.22	0.69	0.96	0.91	0.96	0.86	0.88
150C perf/25mm Mineral Wool/200mm air space	0.30	0.74	0.88	0.58	0.71	0.70	0.73
Perf tile/25mm Mineral Wool/200mm air space	0.50	1.00	1.02	1.07	1.06	1.05	1.04
Perf tile/acoustic Wool/200mm air space	0.48	0.93	0.62	0.69	0.80	0.75	0.76
Mineral Fiber Tile	0.13	0.29	0.47	0.58	0.57	0.54	0.48
GRG T 206, no holes	0.09	0.10	0.10	0.12	0.25	0.35	0.14
GRG T 206, no holes/25MW	0.20	0.40	0.55	0.10	0.21	0.50	0.32

Perforated Metal Tile



Perforated Tile with Non-Woven Acoustic

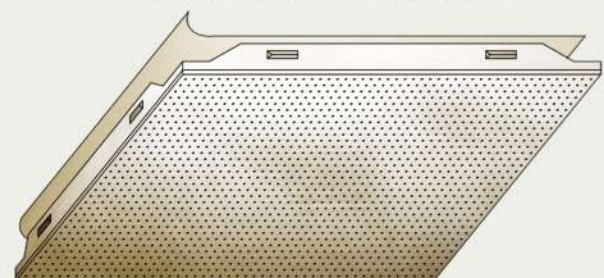

FIRE RESISTANCE

All TRAC® ceilings provide Class 1 Surface Spread of Flame in accordance with BS 476-part 7 (1987). The materials are incombustible as per BS 476-part 4 (1970) and satisfy Class O as per BS 476-part 6 (1989).

84R Interior & Exterior Ceilings

84R INTERIOR

Material

Panels: 84mm wide x 16mm deep, made out of 0.50mm aluminium alloy AA3105 with stove enamelled coil coated finish / 0.45 galvanised steel with stove enamelled coil coated finish.

(Colour according to TRAC® colour chart and availability chart)

Panel length upto approx 5m

When perforated, hole diameters are 2mm on 5mm centres (standard) or 1mm on 2.5mm centres (microperforated), the holes representing 15% of the perforated area.

Panel Carriers: 32mm wide, 39mm deep, made out of 0.95mm aluminium alloy 0.6mm galvanised steel, with prongs to hold the panels in a module of 90mm/100mm (gap 6/16mm, open). Optional gap closures with recessed or flush join profiles for 16mm gap.

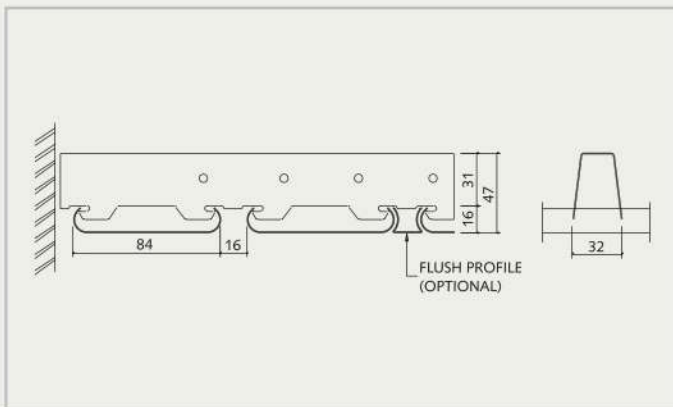

Flush join Profiles : Made of enamelled aluminium, for 100mm module (16mm gap).

Suspension: By means of suspension rods and spring clips. One suspension for every 1.5 to 2 sq.m.

Panel Span: 1.3m max. with insulation, 1.5m max. without insulation.

Carrier Span: 1.3m max. spacing of suspension rods.

Finish

Coil Coated: Panels will be finished on exposed side with 20 microns polyester coil coating over primer and on rear side with a wash coat.

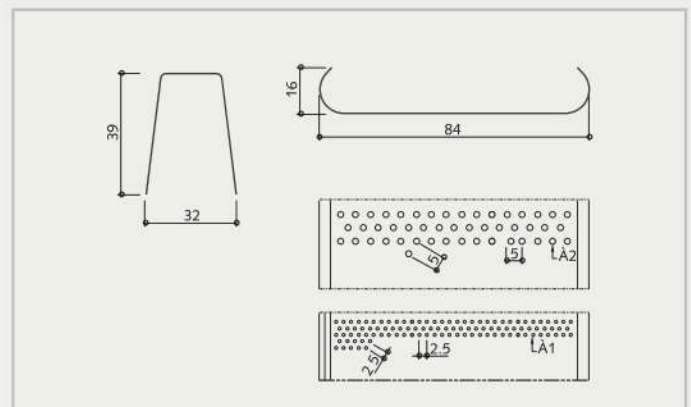

Suspension: By means of rigid suspension rods or on steel substructure.

Panel Span: 800mm max.

Stringer Span : 500mm max. spacing of suspension angles.

84R EXTERIOR

Material

Panels: 84mm wide x 16mm deep, made out of 0.60mm aluminium alloy AA3105 with stove enamelled coil coated finish.

(Colour according to TRAC® colour chart and availability chart)

Panel length upto approx 5m

Stringers: 34.5mm wide, 48mm deep, made out of 0.95mm aluminium alloy, with prongs to hold the panels in a module of 90mm / 100mm (gap 6 / 16mm open). Optional gap closure with flush join profile for 16mm gap.



84R with Flush Profile

Sound Absorption Data

Frequency, Hz	125	250	500	1000	2000	4000	NRC
84R perf/25mm Mineral Wool/200mm air space	0.22	0.69	0.96	0.91	0.96	0.86	0.88

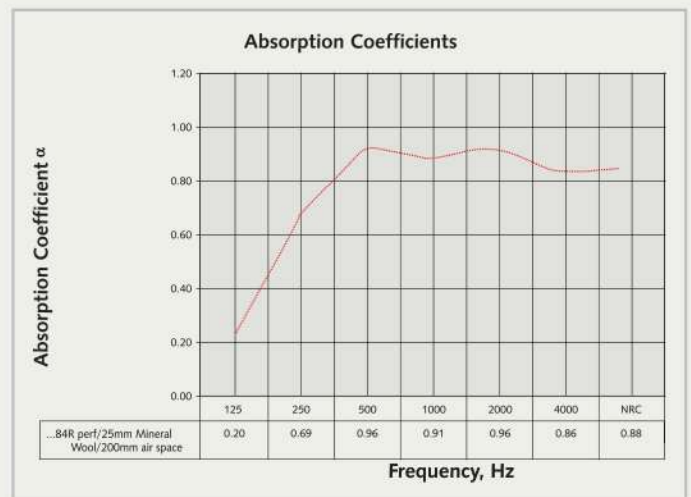

84R Interior & Exterior Ceilings



84C/184C Interior & Exterior Ceilings

84C/184C INTERIOR

Material

Panels: 84mm/184mm wide x 12.5mm deep, with a recessed flange of 23.5mm, made out of 0.50mm aluminium alloy AA3105 with stove enamelled coil coated finish 0.45mm galvanised steel with stove enamelled coil coated finish.

(Colour according to TRAC® colour chart and availability chart)

Panel lengths up to approx. 5m

Panel carriers: 32mm wide, 39mm deep, made out of 0.95mm aluminium alloy 0.6mm galvanised steel, with cutouts to hold the panels in a module of 100mm (84C) or 200mm (184C), gap 16mm closed.

Suspension: By means of suspension rods and spring clips. One suspension for every 1.5 to 2 sq.m.

Panel Span: 1.3m max. with insulation, 1.6m max. without insulation.

Carrier Span: 1.3m max. spacing of suspension rods.

Finish

Coil Coated: Panels will be finished on exposed side with 20 microns polyester coil coating over primer and on the rear side with a wash coat.

84C EXTERIOR

Material

84C ceilings can also be used for exterior applications when suspended by rigid suspension rods or mounted on a steel substructure. 84C exterior ceiling is available in 0.50mm aluminium alloy AA 3105 with stove enamelled coil coated finish.

(Colour according to TRAC® colour chart and availability chart)

Carrier Span: 500mm max. spacing of suspension angles.

Finish

Coil Coated: Panels will be finished on exposed side with 20 microns polyester coil coating over primer and on rear side with a wash coat.

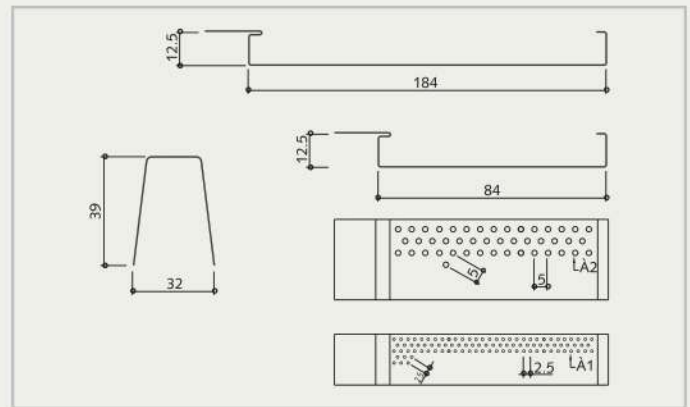

84C Ceiling System

Sound Absorption Data

Frequency, Hz	125	250	500	1k	2k	4k	NRC
84Cperf/25mm Mineral Wool/200mm air space	0.38	0.90	1.08	10.2	1.10	0.79	1.03

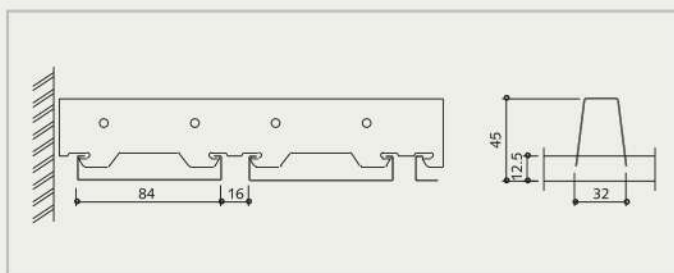

84C/I 84C Interior & Exterior Ceilings



Clip-in-Tile & Lay-in Grid Tile Ceilings System

TRAC® tile ceiling system has been developed to meet both practical and aesthetical requirements of modern ceilings. The major advantages of the TRAC® tile system are innovative suspension systems, optional rigid grid system for suspension of exterior ceilings, choice of tile material, extensive range of colours and finishes and a choice of perforations and flexibility in design specially with the ceiling system. The tile ceiling systems are offered in stove enamelled coil coated steel and aluminium and powder coated steel and aluminium finishes and offer the advantage of easy cleaning, non-static properties and inert material.

Incandescent and halogen type spot lights can be easily incorporated in the tile ceilings and fluorescent fittings within the ceilings.

Tiles

Tiles are manufactured out of coil 0.7mm coated galvanised steel/aluminium alloy AA 3105 on advanced equipment, which includes several levelling stages in the manufacturing process. For the clip-in tile, two sides of each tile are raised and pipped and stopped to ensure positive engagement into the spring tee yet allow demounting of individual tiles.

For the lay-in system, the tiles have a flange on each end which lays on the exposed grid. All tiles have square/bevelled edges.

Suspension

Clip-in-system: Tiles are suspended by means of a suspension system comprising 0.5mm galvanised steel clip-in profiles installed at correct spacing to support the tiles. Suspension profiles are suspended from roof structure by GI ceiling brackets. GI suspension angles and hold-on clamps at max. 1200mm centre to centre along the clip in profile. This rigid suspension is also suitable for exterior use.

Lay-in-System: Suspension system is standard 24mm table exposed metal grid. Grid features 38mm high main runners and cross tees, roll formed from galvanised steel to BS 2989 Z-18 zinc coating. The main runners feature bayonet ends and the cross tees stab ends for quick and simple coupling. The runners are pre-slotted to construct a variety of layouts. The main and cross runners are provided with a coil coated steel capping on the exposed table in off-white colour. The grid is suspended from the roof with GI wire rod and quick adjustment suspension hangers along the runners. The grid system is designed to satisfy ASTM C635 intermediate duty loading and deflection criteria. This system is only suitable for interior use.

Edge Cover Profile

Tiles are trimmed along the wall perimeter by means of 19x19mm roll formed steel or aluminium edge cover profile.

MATERIAL

Aluminium - Coil Coated Clip-in / Lay-in Grid Tiles

Aluminium - Powder Coated Clip-in / Lay-in Grid Tiles

Steel - Coil Coated Clip-in / Lay-in Grid Tiles

Steel - Powder Coated Clip-in / Lay-in Grid Tiles

Paint Finish

Steel tiles : Steel tiles are finished on exposed side with 20 micron polyester coil coating over primer in approved shade and backing coat on rear surface (nominal 5 microns), or with a 80-100 micron epoxy polyester powder coating on exposed surface.

Aluminium tiles : Aluminium tiles are finished on exposed side with 20 micron polyester Coil Coated Factory painted over primer in approved shade and backing coat on rear surface (nominal 5 microns), or with a 50 micron epoxy polyester powder coating on exposed surface. Wall angles are finished with 50 micron epoxy polyester powder coating paint in broken white shade.

Perforations

TRAC® tiles are also available with perforations for providing acoustic performance characteristics. TRAC® tiles are perforated as a standard with 2.5mm dia. holes at 5.5mm centre to centre in a regular pattern. Other special/non-standard perforations are also available. Tiles when backed with 25mm thick resin bonded mineral wool (48 kg/m³) provide good sound absorption. Tiles are also available with a factory applied acoustic tissue to the back side, which provides good sound absorption.

Sound Absorption Data

Frequency, Hz	125	250	500	1k	2k	4k	NRC
Perf Tile/Acoustic tissue	0.48	0.93	0.62	0.69	0.80	0.75	0.76
Perf Tile/ 25mm Mineral Wool	0.50	1.00	1.02	1.07	1.06	1.05	1.04

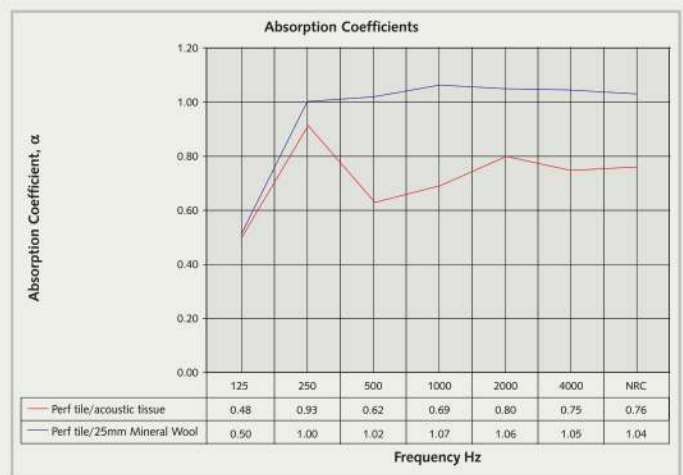

Tiles Ceiling System

Clip-in-Tile & Lay-in Grid Tile Ceilings System



I 50F Interior & Exterior Ceilings / I 50C Interior

150F INTERLOCK PANEL (INTERIOR / EXTERIOR)

INTERIOR

Material

Panels: 150mm wide x 17mm deep, made out of 0.60mm aluminium alloy AA 3105 with stove enamelled coil coated finish / 0.50mm galvanised steel with stove enamelled coil coated finish.

(Colour according to TRAC® colour chart and availability chart)

Panel length upto approx 5m

Stringers: 34.5mm wide, 48mm deep made out of 0.95mm aluminium alloy AA5052/0.60mm galvanised steel, with prongs to hold the panels in a module of 75/150mm.

Suspension: By means of suspension rods and spring clips.

Panel Span: 1.5m max. with insulation, 1.8m max. without insulation.

Stringer Span: 1.5m max. spacing of suspension rods.

Finish

Coil Coated: Panels will be finished on exposed side with 20 microns polyester coil coating over primer and on the rear side with a wash coat.



I 50F Ceiling System

EXTERIOR

Material

Panels: 150mm wide x 17mm deep, made out of 0.60mm aluminium alloy AA3105 with stove enamelled coil coated finish / 0.50mm galvanised steel with stove enamelled coil coated finish.

(Colour according to Trac colour chart and availability chart)

Panel length up to approx 5m

Stringers: 34.5mm wide, 48mm deep made out of 0.95mm aluminium alloy AA 0.60 mm galvanised steel, with prongs to hold the panels in module of 150mm.

Suspension: By means of rigid suspension angles or mounted on a steel sub-structure.

Panel Span: 1000mm max.

Stringer Span: 500mm max. spacing of suspension angles.

Finish

Coil Coated: Panels will be finished on exposed side with coil coated stove enamelled PVF2/polyurethane/SMP paint with a wash coat on rear side.

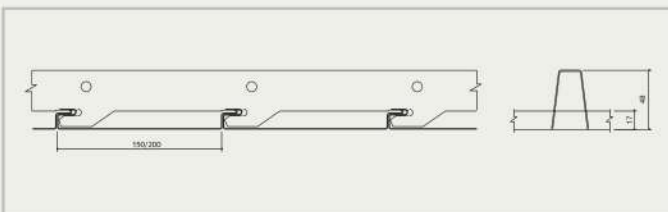

150C INTERIOR

TRAC® ceiling type 150C distinguishes itself from the other types because of its smooth, closed appearance. The panels abut each other with a narrow V-groove. They are installed to carrier profiles and can be simply demounted individually, by inserting a plain strip between the profiles.

As with all TRAC® ceilings, the 150C can be applied in all types of buildings and because of their closed appearance they are particularly suitable for domestic applications: living rooms, kitchens, corridors etc.

Panels: 150mm wide x 15mm deep with bevelled groove between panels, made out of 0.50mm thick aluminium alloy AA 3105 or 0.5mm thick galvanised steel.

(Colour according to TRAC® colour chart and availability)

Panel lengths upto approx 5 m.

When perforated, hole diameters are 2mm on 5mm centres (standard) or 1mm on 2.5mm centres (micro-perforated), the holes representing 15% of the perforated area (150C only).

Panel Carriers: 32mm wide, 39mm deep made out of 0.95mm aluminium or 0.6mm galvanised steel, with prongs to hold panel in a module of 15mm.

Suspension: By means of G.I. rod hangers and suspension clips.

Panel Span: 1.3m max. with insulation, 1.5m max. without insulation.

Carrier Span: 1.3m max. spacing of suspension rods.

Finish

Coil Coated: Panels will be finished on exposed side with coil coated stove enamelled PVF2/polyurethane/SMP paint with a wash coat on rear side.

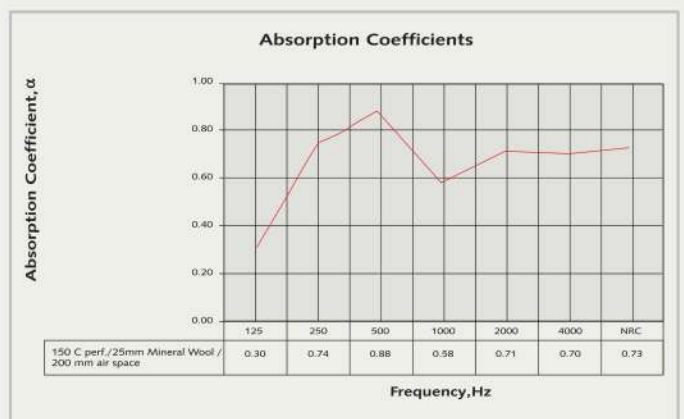

Sound Absorption Data

Frequency, Hz	125	250	500	1k	2k	4k	NRC
150C perf./25mm Mineral Wool/200mm air space	0.30	0.74	0.88	0.58	0.71	0.70	0.73

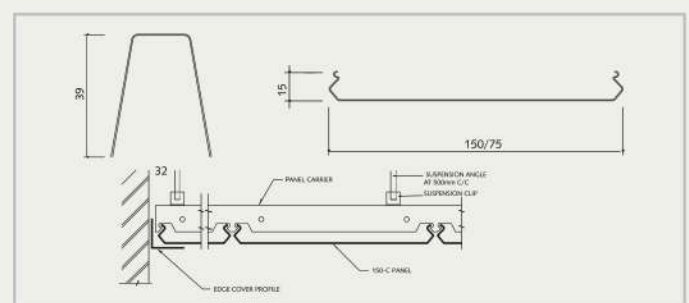

I 50F Interior & Exterior Ceilings / I 50C Interior



Indian Oil Corporation Ltd



Reliance Petroleum



Hindustan Petroleum Corporation Ltd



Bharat Petroleum Corporation Ltd



Essar Oil Ltd



GAIL India Ltd

Cross Section of Various Ceilings Systems

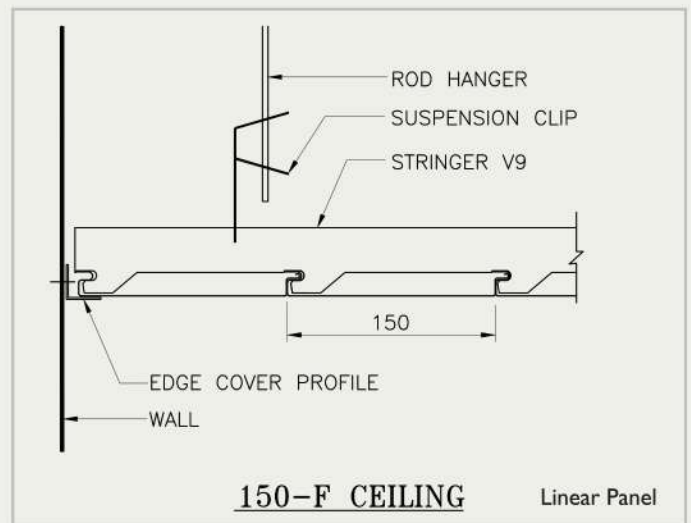
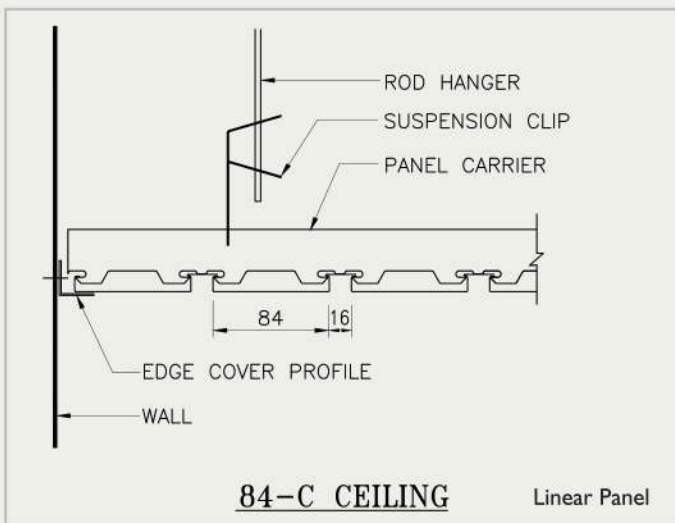
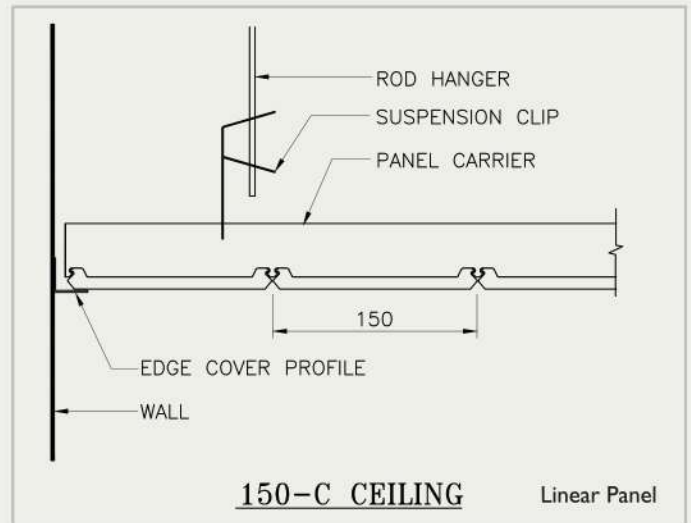
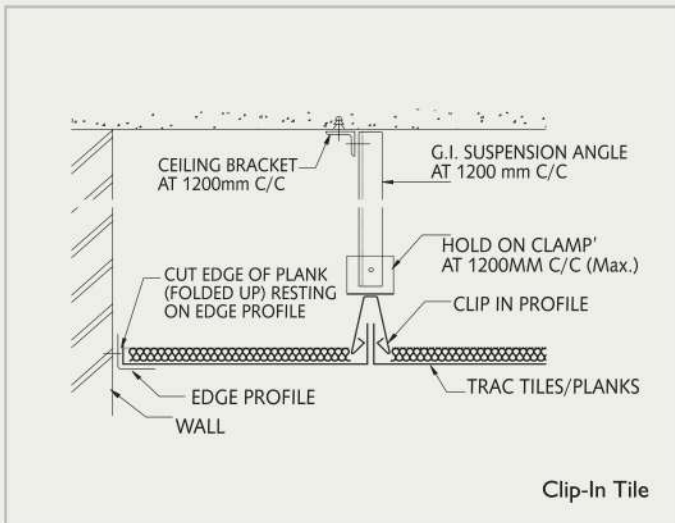
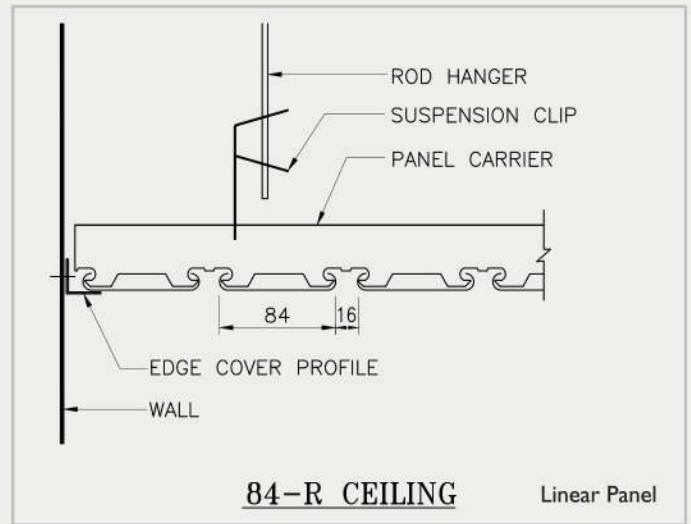
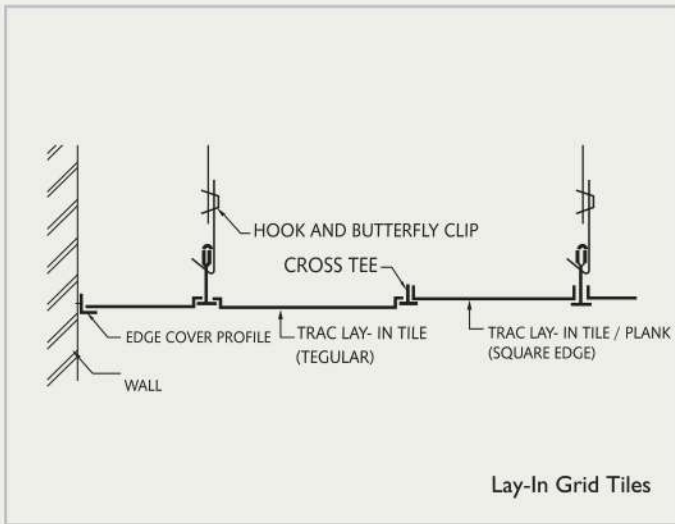

CEILING 150F



LAY-IN SUSPENSION

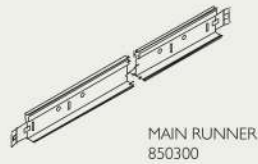

CEILING 200F/CLIP IN TILE & PLANK

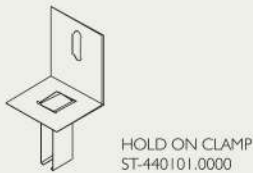
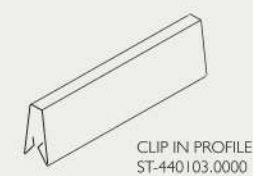

CEILING 84R

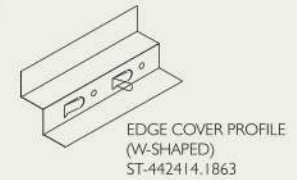
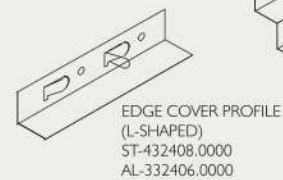

CEILING 84C/184C/84R

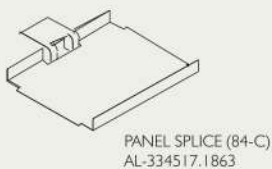
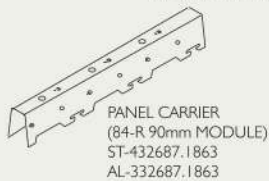

CEILING 150C

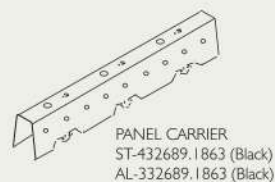

List of Major Projects with TRAC® Ceiling System

S.NO.	Project Name	Location
1.	Schools & Colleges	
	Delhi Government School	13 Locations in Delhi
	Delhi Public School	Rewari
	Blind Relief School	New Delhi
	Thapar University	Patiala
	Punjab Institute of Medical Science	Jalandhar
	All India Institute of Medical Sciences	New Delhi
	Indian Institute of Technology	Kanpur
	Sanskriti School	New Delhi
	National Institute of Biologicals	Noida
	Indian Agricultural Research Institute	New Delhi
Indira Gandhi National Forest Academy	New Delhi	
2.	Oil & Gas	
	Indian Oil Corporation Ltd	All India
	Hindustan Petroleum Corporation Ltd	All India
	Bharat Petroleum Corporation Ltd	All India
	Reliance Petroleum Ltd	All India
	GAIL India Ltd	Rajasthan
	Essar oil Ltd	New Delhi
3.	Transportation Infrastructure	
	Mumbai Airport (International Terminal)	Mumbai
	Bangalore Airport (Public Lounge Area)	Bangalore
	Hyderabad Airport (Public Lounge Area)	Hyderabad
	Raipur Airport (Public Lounge Area)	Raipur
	Chennai Airport	Chennai
	Bhopal Airport	Bhopal
	Delhi Metro Rail Corporation	New Delhi
	Bangalore Metro Rail Corporation Ltd	Bangalore
	Gujarat Metro Rail Corporation Ltd	Ahmedabad
	Lokpriya Gopinath Bordoloi Airport	Guwahati
	Lilabari Airport	Lakhimpur
	Bagdogra International Airport	Siliguri
	Maharaja Bir Bikram Airport	Agartala
Tezpur Airport	Tezpur	
4.	Hospitals	
	Lilavati Hospital and Research Centre	Mumbai
	Medanta -The Medicity	Gurgaon
	Indraprastha Apollo Hospital	New Delhi & Chennai
	Indian Spinal Injuries Centre	New Delhi
	Army Hospital Research and Referral (R&R)	New Delhi
	Escorts Heart Institute and Research Centre	New Delhi
	Guru Nanak Hospital	Mumbai
	Lok Nayak Jai Prakash Narayan Hospital	New Delhi
	Dr. Ram Manohar Lohia Hospital	New Delhi
Tilganga Eye Hospital	Kathmandu	

List of Major Projects with TRAC[®] Ceiling System

S.NO.	Project Name	Location
	Indira Gandhi Memorial Hospital	Maldives
	Indira Gandhi Children's hospital	Kabul
	Employees' State Insurance Corporation	New Delhi
	Batra Hospital	New Delhi
	Dr. Baba Saheb Ambedkar Hospital	New Delhi
5.	Power Generation & Supply	
	National Thermal Power Corporation	Multiple Location
	NHPC Ltd	Faridabad
	Power Grid Corporation of India Ltd Control Room	All India
	ABB Power Project	Hyderabad
	Jindal Captive Power Plant	Bellary
	Tata Power Company Ltd	Mumbai
	Pragati Power Corporation Ltd.	New Delhi
	Bombay Suburban Electric Supply	Dahanu
	Haryana State Electricity Board	Chandigarh
	Punjab State Power Corporation Limited	Chandigarh
	CESC Ltd	Kolkatta
	Ropar Thermal Power Project	Ropar
	6.	Hospitality
Hyatt Regency		Kolkatta
Jaypee Vasant Continental		New Delhi
Raheja Retreat		Mumbai
India Habitat Centre		New Delhi
McDonald's India		New Delhi/ Mumbai
KFC Restaurants		New Delhi
7.	Government Organizations	
	Central Public Works Department	New Delhi
	Bharat Electronics Ltd	Ghaziabad/ Bangalore
	National Agricultural Science Centre	New Delhi
	National Seed Research and Training Centre	Varanasi
	Rourkela Steel Plant	Rourkela
	Uttar Pradesh Jal Nigam	Lucknow
	Uttar Pradesh Mandi Parishad	Lucknow
8.	Corporates	
	ITC Ltd	Saharanpur
	Wipro Ltd	Bangalore
	Mahindra & Mahindra Ltd	Mumbai
	QualComm India Pvt Ltd	Chennai
9.	Banking Institutions	
	Reserve Bank of India	New Delhi
	State Bank of India	Bangalore
	ICICI Bank Ltd	South India
	Punjab National Bank	Mumbai/ Belapur
	Bank Of Maharashtra	Mumbai

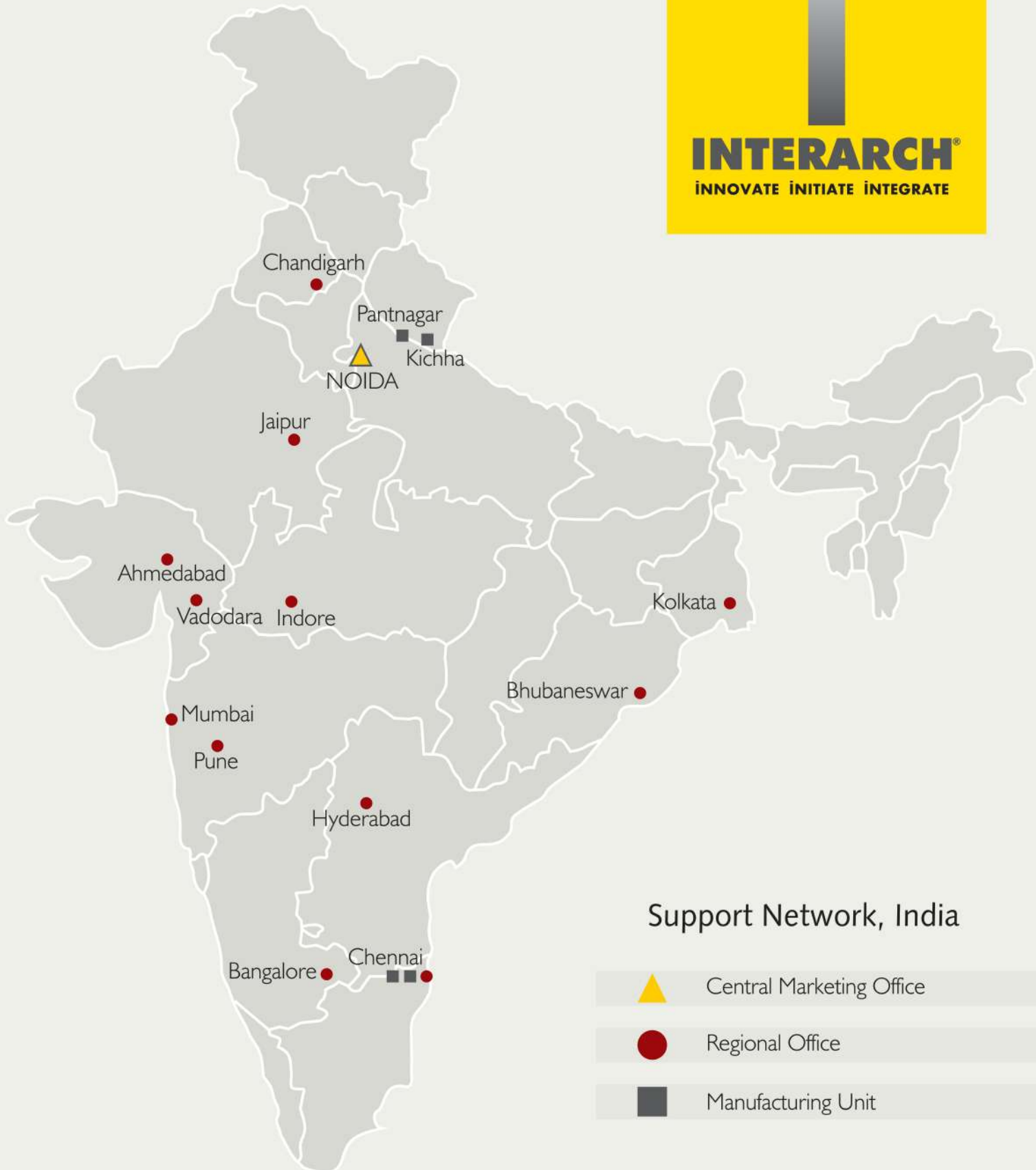

Support Network, India

-  Central Marketing Office
-  Regional Office
-  Manufacturing Unit

Regional Offices & Manufacturing Units

Interarch offers turnkey solutions with regional offices and project control centres for marketing, sales and coordination at all locations across india.

UNIT 1

Plot No. 14, Sector 2,
Integrated Industrial Estate, Pantnagar
Rudrapur - 263153
Uttarakhand
Tel - +91 - 97606 90306, 89793 10068

UNIT 2

Khasra No. 276-A
2 KM on Kichha-Rudrapur Road
Kichha - 263148
Uttarakhand
Tel - +91 - 97606 90306, 89793 10068

UNIT 3

Plot No. D-1/1, SIPCOT Industrial Park,
Mambakkam, Sriperumbudur - 602105
Tamil Nadu
Tel - +91 - 90257 56418, 98402 45569

UNIT 4

Plot No. F-19, SIPCOT Industrial Park,
8th Main Road 1st Cross Street,
Irungattukottai, Sriperumbudur - 602105
Tamil Nadu
Tel - +91 - 81449 24399

For faster processing of enquires from:

Bangalore, Chennai, Hyderabad, Mumbai, Pune, Indore, Ahmedabad, Vadodara, Kolkata, Bhubaneswar, Jaipur & Chandigarh

Central Marketing Office:

B-30 , Sector-57 , Noida-201301

Uttar Pradesh

Tel : 0120 - 4170200

Fax : 0120 - 2581017

E-Mail: info@interarchbuildings.com

Website: www.interarchbuildings.com





INTERARCH BUILDING PRODUCTS PVT. LTD.

AN ISO 9001-2015 COMPANY

Central Marketing Office

B-30, Sector 57, NOIDA - 201 301, INDIA

Tel.: 0120 - 4170200, Fax : +91-120-2581017

E-mail: info@interarchbuildings.com | www.interarchbuildings.com

TRACDEK[®], TRAC[®], are registered trademarks of Interarch Building Products Pvt Ltd

